

HAFNIA

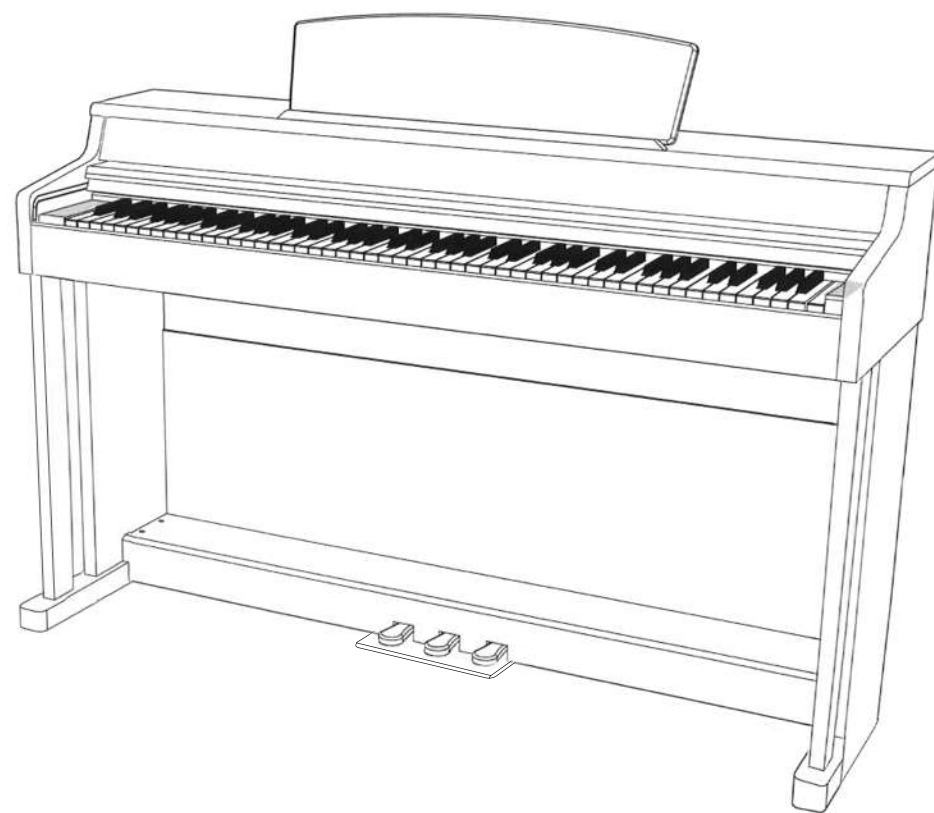

HDP-210
DIGITAL PIANO

USER MANUAL

Thank you for buying a Hafnia Digital Piano!

We appreciate that you have chosen our product, and we are thrilled to have you as part of our musical community. Our team has put great effort into crafting an instrument that combines quality, innovation, and a passion for music.

To fully utilize the functions of this digital piano, we highly recommend that you read this user manual.

We wish you endless creativity and joy with your new digital piano!

H A F N I A

www.hafniapiano.com

CONTENT

OVERVIEW & INTRODUCTION

Panel controls and terminals	02-05
------------------------------	-------

SETTING UP

Key Cover and Music Rest	06
Swichting the Power On/Off	07
Adjusting the Master Volume	07
Using the Triple Pedal	07-08
Bluetooth Connectivity	08
Automatic Power-Off	08
Using Headphones	08
USB to Host Port	08

BASIC OPERATION

Selecting and Playing Sounds(Tone)	09
Transpose Function	09

INSTALLATION INSTRUCTIONS

Included parts	10
Assembly Instructions	11-13

APPENDIX

Troubleshooting	14
-----------------	----

PRODUCT OVERVIEW

•FRENCH DREAM SOUND SOURCE

The core of this product features a new generation French Dream sound source and digital sampling technology, delivering a truly realistic and immersive auditory experience.

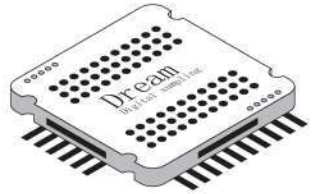

•DUAL HEADPHONE JACKS

The external dual headphone jacks allow for playing without disturbing others, providing a convenient solution for private practice or shared living spaces.

•88 FULLY WEIGHTED KEYS WITH PROGRESSIVE HAMMER ACTION

The 88-key progressive heavy hammer-action keyboard provides a truly realistic touch, resembling the feel of playing on a grand piano.

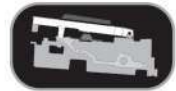

•INSTRUMENTS PARAMETERS

Number of keys: 88	Register: A0 - C8
Number of sounds: 10	Output Power: 10W x2
Style: Desktop Piano	Power supply: AC 100-240V 50Hz

•BLUETOOTH MIDI AND AUDIO

•TRIPLE PEDAL SYSTEM

Triple pedal system that allows you to fully experience the feeling of playing the piano

INTRODUCTION

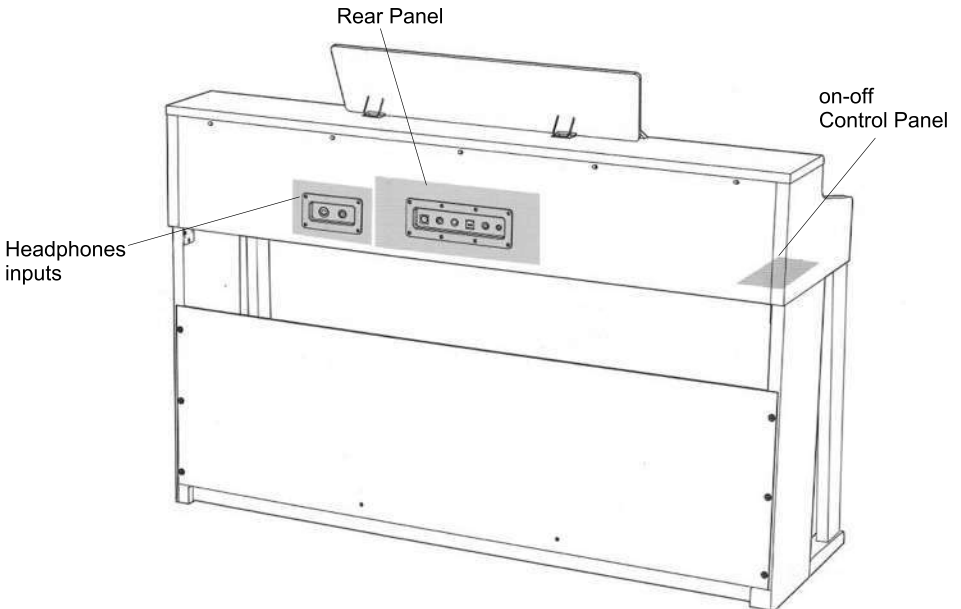
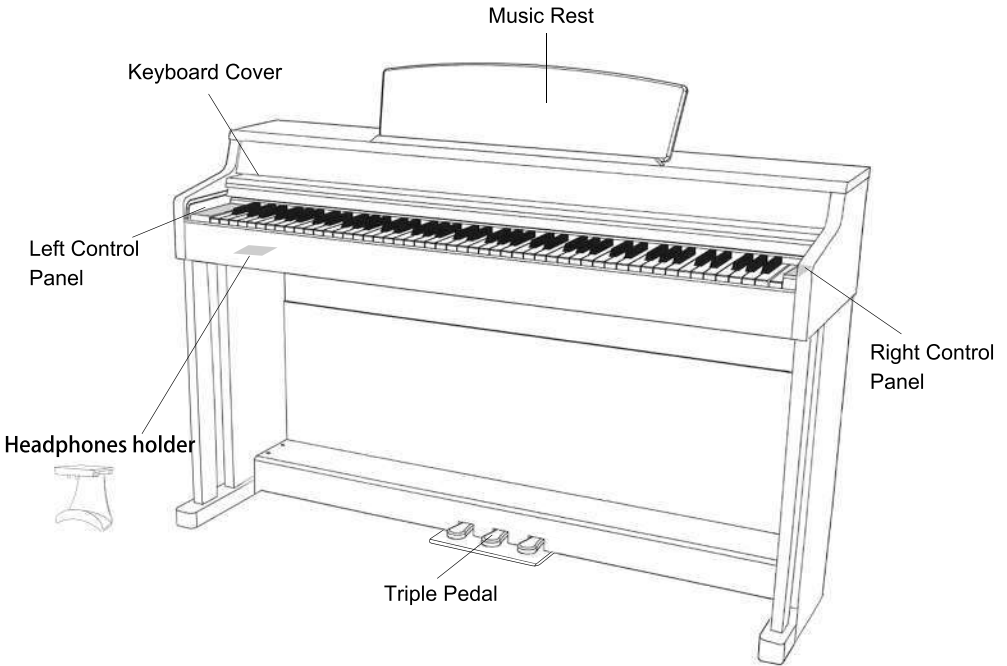

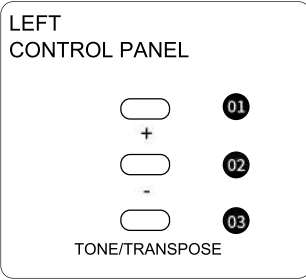

01 **[+] BUTTON**

This button is used to select different "tones" and "transposes".

02 **[-] BUTTON**

This button is used to select different "tones" and "transposes".

03 **[TONE/TRANSPOSE] BUTTON**

This button is used for "tone" and "transpose", click to switch between loops.

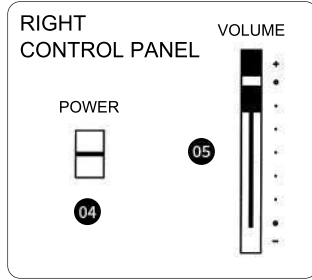

04 **[POWER] BUTTON**

This button is used to turn the power ON/OFF.

05 **[VOLUME] SLIDER**

This slider is used to adjust the overall volume from bottom to top.

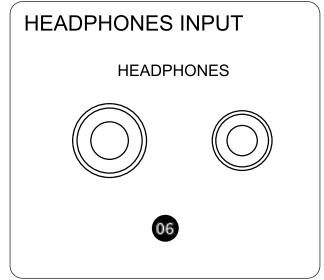

06 **[HEADPHONES] JACKS**

There are two headphone jacks (a 6.35mm and a 3.5mm) to connect headphones.

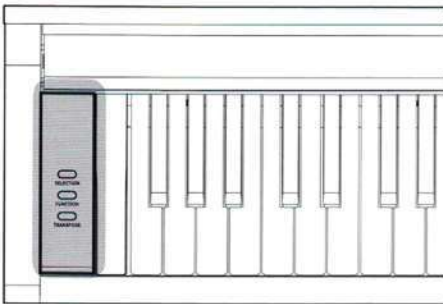

Left Control Panel

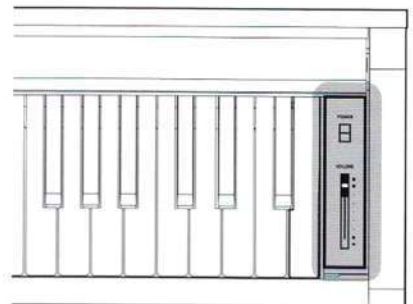

Right Control Panel

HEADPHONE HOLDER



07 * 【HEADPHONES HOLDER】

The headphones holder is a separate component that does not require drilling holes on the piano, just sticking it on. We suggest sticking it to the position on the introduction page. (As shown in the image on the introduction page)

POWER
ADAPTER IN



08

SUSTAIN PEDAL
JACK



09

TRIPLE
PEDAL INPUT



10

USB



11

AUDIO IN



12

AUDIO OUT



13

08 【POWER ADAPTER】 IN

This input is used to connect the Power Adapter.

09 【SUSTAIN PEDAL】 JACK

This jack is used to connect the sustain pedal.

10 【TRIPLE PEDAL】 INPUT

This input is used to connect a triple pedal (pedal unit) with the 5-pin DIN plug.

11 【USB MIDI】 TO-HOST

This USB port is used to connect a computer or a smart device with a USB-MIDI cable.

12 【AUDIO IN】

This input is used to connect external audio input.

13 【AUDIO OUT】

This output is used to connect external speaker devices.

SETTING UP

Key Cover and Music Rest

■ Opening the Key Cover

Lift the cover slightly, then push and slide it to the end.

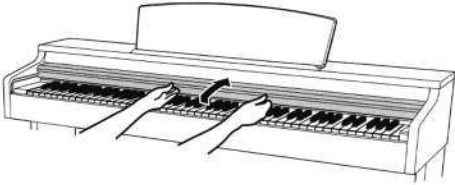

■ Closing the Key Cover

Slide the cover toward you and gently lower the cover over the keys.

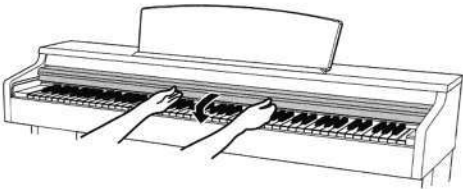

*Do not place objects such as pieces of paper or metal on top of the key cover. It may fall inside the unit when the cover is opened and may be nearly impossible to remove. This could cause electric shock, short circuit, fire or other serious damage to the instrument.

Hold the cover with both hands when opening or closing it. Do not release it until it is fully opened or closed. Be careful to avoid catching fingers (especially children's) between the cover and the unit.

■ To Raise the Music Rest

- 1 Pull the music rest up and toward yourself as far as it will go.
- 2 Flip down the two metal supports at the left and right on the rear of the music rest.
- 3 Lower the music rest till the metal supports latch into place.

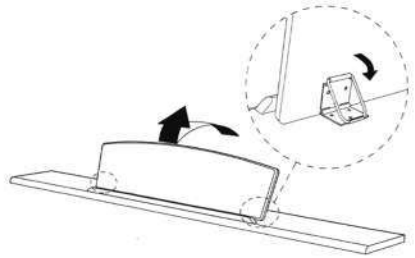

■ To Lower the Music Rest

- 1 Pull the music rest toward yourself as far as it will go.
- 2 Raise the two metal supports.
- 3 Gently lower the music rest backwards until it lays flat.

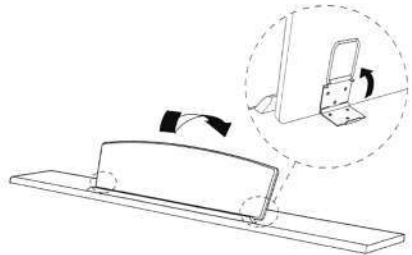

*Make sure the music rest been pulled completely when raising or lowering. And do not release your hands from the music rest during raising or lowering.

SETTING UP

Turning the Power On/Off

Press the (POWER) button located on the Right Control Panel, the LED indicator for the (SELECTION) button will turn on when the power is turned on.

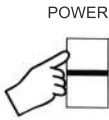

* Please do not take any other operations when pressing power button, such as pressing the keyboard, buttons or pedals may cause the instrument to malfunction.

Adjusting the Master Volume

Drag the (VOLUME) slider on the Right control Panel to adjust the Master Volume to a suitable level.

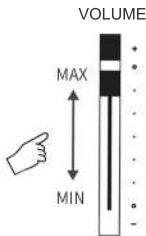

Using the Triple Pedal

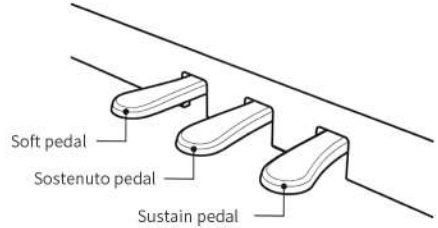

■ Sostenuto pedal (center pedal)

If you play a note or chord on the keyboard and press the sostenuto pedal while holding the note(s), the notes will sustain as long as the pedal is held. All subsequent notes will not sustain.

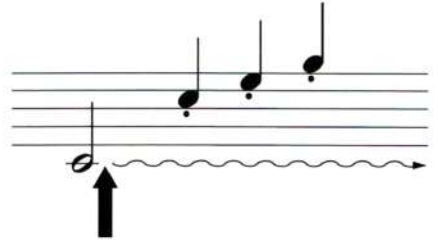

■ Sustain pedal (right pedal)

When you press the damper pedal, the notes you play have a longer sustain

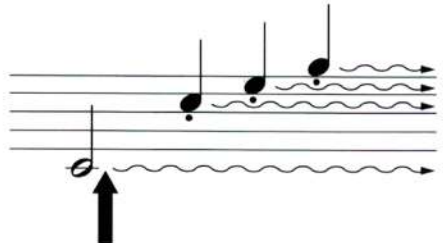

SETTING UP

■ Soft pedal (left pedal)

The soft pedal reduces the volume and slightly changes the timbre of notes played while the pedal is pressed. The soft pedal will not affect notes that are already playing when it is pressed. In order to apply this effect play notes after pressing the pedal

Bluetooth connectivity

■ Audio Bluetooth:

This device supports both IOS and Android systems. First, turn on the power switch of the digital piano, then turn on the Bluetooth function of the phone, and search for the device on the phone. Its Bluetooth name is Hafnia. After successful connection, it can play songs on the phone or iPad.

■ MIDI Bluetooth:

First turn on the power switch of the electric piano, then turn on the Bluetooth function of the phone, select Bluetooth connection in the APP and after successful connection, the digital piano and APP communicate with each other.

Automatic power-off

After playing the digital piano, if you forget to turn off the piano on-off, the piano will automatically power off after 30 minutes. If you want to continue playing the piano, please turn on the power again.

Using Headphones

The piano features 2 headphone inputs (a 6.35mm and a 3.5mm). When the headphones are plugged into either of the headphone inputs, the internal speaker system is automatically shut off.

Headphone Jacks

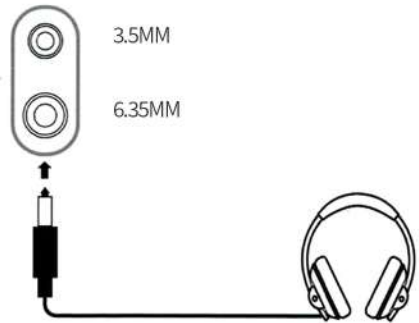

*When connect to headphone jack, we suggest to adjust the volume to the minimum. And do not use headphones at a high volume for an extended period of time.

USB to Host port

Use the [USB MIDI] input (Type B) located on the Rear Panel to connect a computer or smart devices to receive or send MIDI data

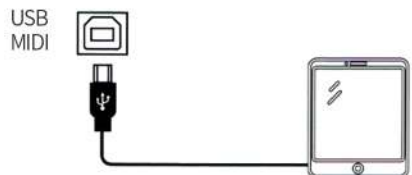

SELECTING AND PLAYING SOUNDS(TONE)

The digital piano features 10 built-in advanced Tones.

NO.	VOICE NAME	NO.	VOICE NAME
01	Grand Piano	06	Upright Piano
02	Bright Grand Piano	07	Harpsichord
03	E.Piano 1	08	Vibraphone
04	E.Piano 2	09	Organ
05	Mellow.grand Piano	10	Strings

*The default tone is NO.1 tone, and other tones can be selected using "+" and "-"

TRANPOSE FUNCTION

CONTENT	ADJUSTMENT SCOPE
Transpose	+12...0...-12

*The initial default is "0", which can be selected through "+" and "-"

INCLUDED PARTS

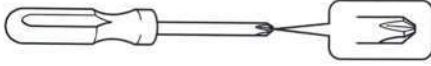

A Phillips-head (+) screwdriver (not included) will be required in order to assemble the instruments.

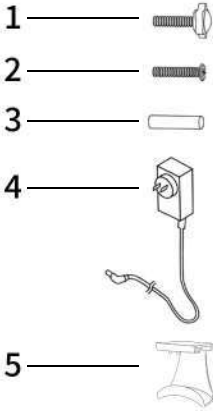

NO.	NAME	QUANTITY
A	Pedal board	1 PCS
B	Left Side panel	1 PCS
C	Right Side panel	1 PCS
D	Center board	1 PCS
E	Piano leg	2 PCS
1	Thumb screw	4 PCS
2	M5x30mm screw	12 PCS
3	Wooden plugs	8 PCS
4	Adapter	1 PCS
5	Earphone holder	1 PCS

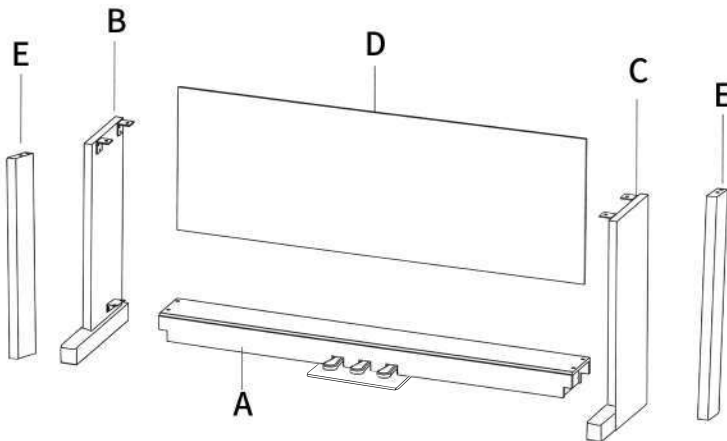

Assembly Instructions

■ Attaching the side panels to the pedal board

- 1 Unfasten and extend the pedal connection cable attached to the bottom of the pedal board.

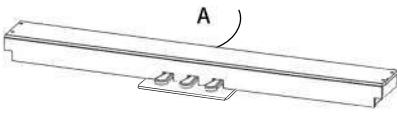

- 2 Attach the pedal board (A) to the left (B) and right (C) side panels located on either end of the pedal board. Insert the four screws (2) into the holes as shown, and securely fasten the pedal board to the left and right side panels.

2  4 PCS

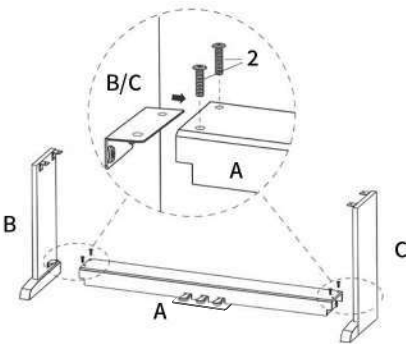

■ Attaching the back board

- 1 Allow the assembled pedal board (A) and side panels (B&C) to stand upright (vertically) on the floor.
- 2 Attach the center board (D) to the left and right side panels (B&C) using the six screws (2).
- 3 Attach the bottom of the center board (D) to the pedal board (A) using the two screws (2).

2  8 PCS

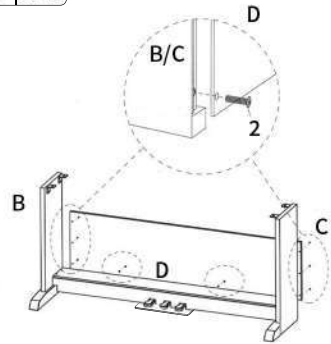

■ Mounting the main body onto the stand

- 1 Attach 4 wooden plugs (3) on each leg (E). Then fasten the legs to the stand.

3  8 PCS

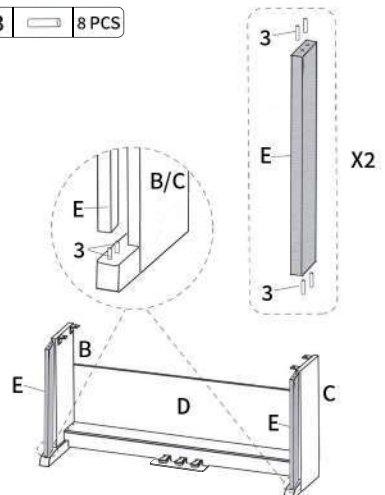

- 2 Lift the digital piano and carefully place it onto the stand.

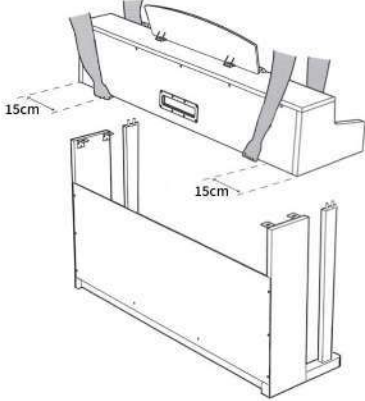

*When lifting the main body onto the stand, be careful not to catch/trap hands and fingers. We suggest to place your hands atleast 15 cm away from either end of the main unit when positioning it.

- 3 Align the wooden plugs on the legs with the hole at the bottom of either end of the piano.

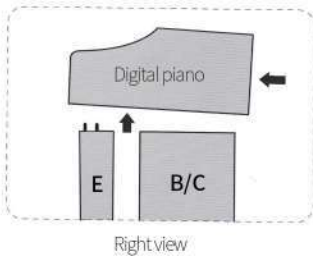

- 4 Gently slide the main body backward until the hole location of the main body is aligned with the bracket holes on the base

■ Fastening the main body to the stand

- 1 When positioned correctly, the attachment screw holes should be visible from the underside of the main unit.

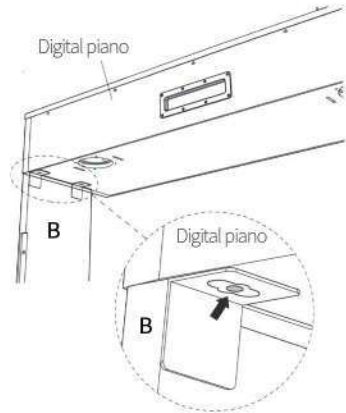

- 1 View the front of the instrument to ensure that the digital piano are in the center position of stand. The left and right endsside of digital piano will project beyond B&c equally

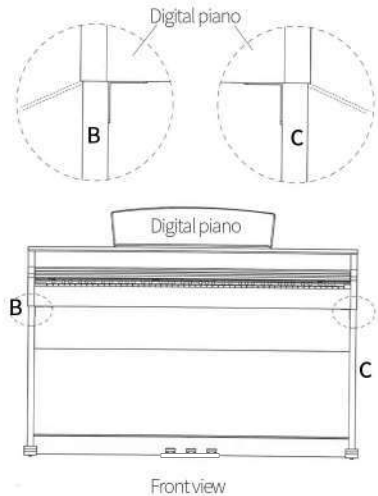

- 3 Then secure main body by tightening four screws(1)from the front.

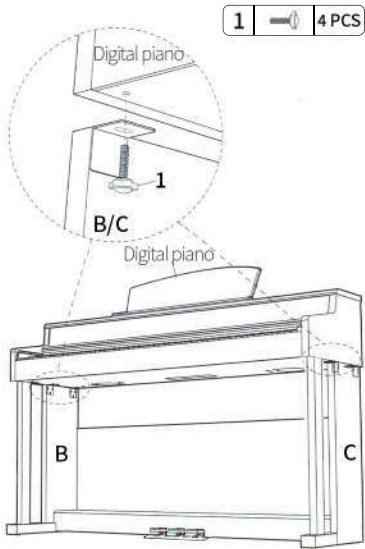

TROUBLESHOOTING

	PROBLEM	POSSIBLE CAUSE AND SOLUTION
POWER	The instrument does not turn on.	The instrument has not been plugged in properly. Securely insert the female plug into the socket on the instrument and the male plug into a proper outlet.
	A click or pop is heard when the power is turned on or off	This is normal when electrical current is being applied to the instrument.
SOUND	The instrument is turned on, however no sound is produced when the Keys are pressed.	Check that if the MASTER VOLUME knob is set to the lowest. And check if the HEADPHONES JACK has been connect
	Noise is heard from the speakers or headphones.	The noise may be due to interference caused by the use of a mobile phone in close proximity to the instrument Turn off the mobile phone, or use it further away from the instrument
	Noise is heard from the instrument's speakers or headphones when using the instrument with the application	When you use the instrument along with the application on your iphone/ipad, we recommend that you set that device's "Airplane Mode" to "ON" and then the Wi-Fi setting to "ON" on your iphone/ipad in order to avoid noise caused by communication.
	The sound distorts when playing at very loud volume levels.	Check that the MASTER VOLUME knob is set to an appropriate level, reducing the volume if excessive distortion is heard.
	The overall volume is low, or no sound is heard.	The Master Volume is set too low; set it to an appropriate level using the [MASTER VOLUME] knob.
PEDAL	Pedals do not function,	The pedal cord may not be securely connected to the [PEDAL] jack. Be sure to insert the pedal cord all the way until the metal part of the cord plug disappears from view.